

# IAB Conference Industry Attendees

Company	Name(s)
AboveNet	Kathy Nguyen
Alcatel-Lucent	Dan Kilper
Ericsson	Stefan Dahlfort, Mallik Tatipamula
Fiber Network Engineering	Marcus Nebeling
Fujitsu Network Communications	Don O'Connor
Hewlett Packard	Michael Tan, Alex Bratkovski
Intel	Peter Chang
IFOS	Richard Black
Kotura	Mehdi Asghari, Arlon Martin
Magnolia Solar	Jim Egerton
Nistica	Ashish Vengsarkar
Nitto Denko Technical	Michi Yamamoto
Telemetry Tech.	Kaveh Hushyar
VPI Systems	Andre' Richter
Yokogawa	Michael Kwok



---

# CIAN IAB

San Jose, CA  
November 2, 2010

N. Peyghambarian, S. Fainman and J. Sanchez



# CIAN and Its Vision

---

- CIAN is an NSF funded program: ~ \$50M over 10 years
- Just started the third year of its operation

The vision of CIAN is to create disruptive technologies for optical access aggregation networks, interfaced with core networks in a cost effective manner.

Through commercialization efforts and industry partnership CIAN will enable a business ecosystem that creates affordable and flexible access to any type of services to consumers any where, at any time.



# The CIAN Team



# Strategic Research Plan

## Optical Commun. Systems and Networks

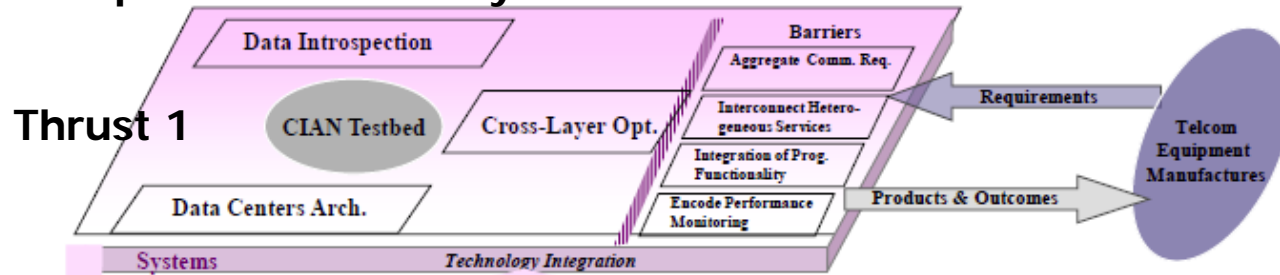

## Integrated Subsystems

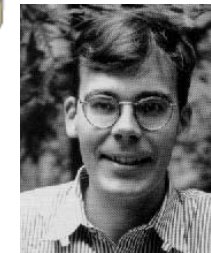
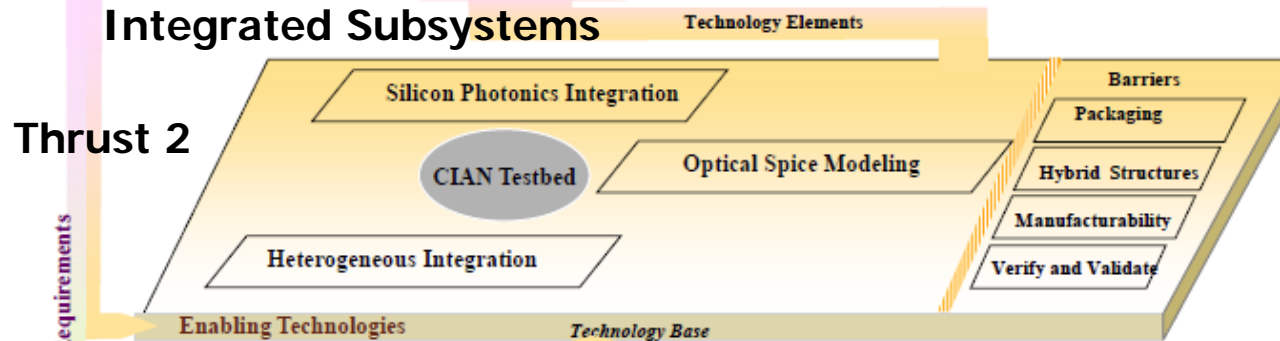

## Materials and Devices

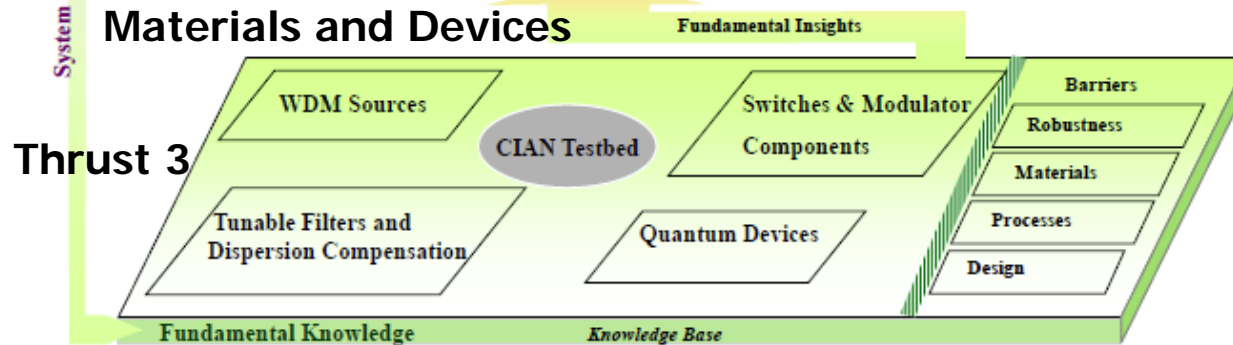

# Working Group 1



**Thrust 1:**  
Optical Communication Systems & Networking

**Thrust 2:**  
Subsystem Integration & Silicon Nanophotonics

**Thrust 3:**  
Materials & Devices

**Kueppers, UA**  
**Radic, Papen, UCSD**

Testbed Leads:



**Working Group I:**  
Scalable & Energy Efficient Data Centers

**Working Group II:**  
Intelligent Aggregation Networks

**Data Center Testbed**  
UCSD

**Aggregation, System Integration & Wireless backhaul Testbeds**  
UA, UCSD, Columbia

**System Testbeds**

**Data Introspection & packaging**  
USC, Berkeley

**Chip-Scale Testing Facility**  
UCSD

**Satellite Testbeds**

**CIAN's Distributed Testbed Infrastructure**

**Applications:**

- Energy-aware and cost-aware switching
- Virtual data centers

**Applications:**

- Energy-aware switching & routing
- wireless backhaul for seamless mobile internet
- Large data aggregation applications such as Full HD 3D & Telepresence

# Working Group 2

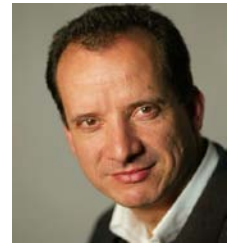

**Research Projects**

**Research Projects**

**Research Projects**

# WG1: The Need for Lower Cost, more Energy Efficient Data Centers

## Google's 36 Worldwide Data Centers



Walmart's Data Center

## "Cloud" Computing

- Massive migration of computing and storage into relatively small number of dense data centers

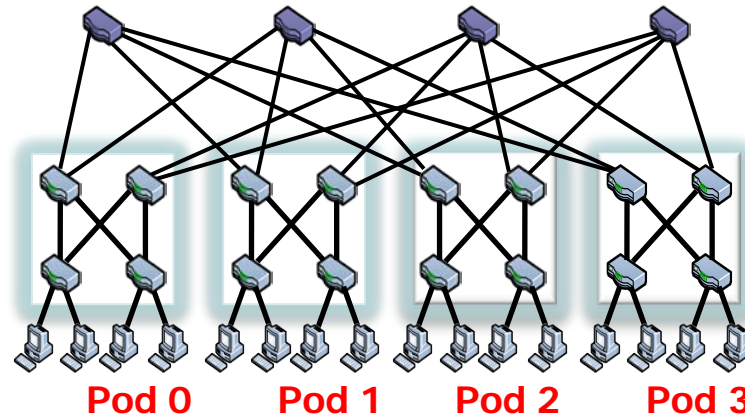

## Goals:

- Develop novel scalable architectures for cost effective and energy efficient operation of data centers
- Develop photonic technology in support of optical communication

# WG2: More Efficient, Smart Bandwidth, Not Just Fatter Pipes

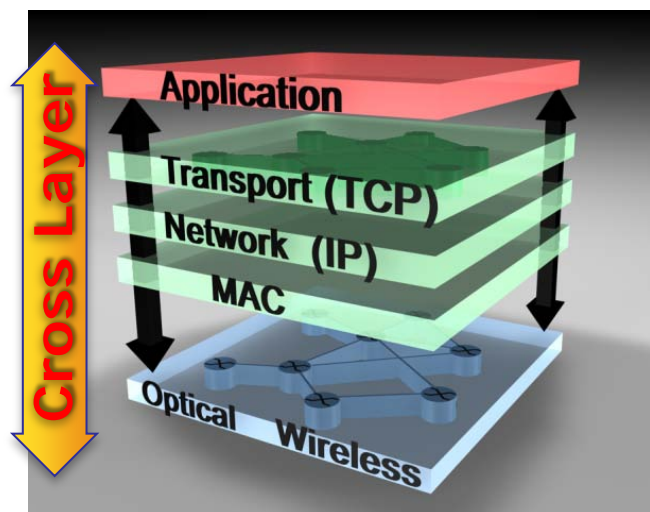

## Traffic Flows of the Future

- Heterogeneous mix of flows with distinct QoS requirements

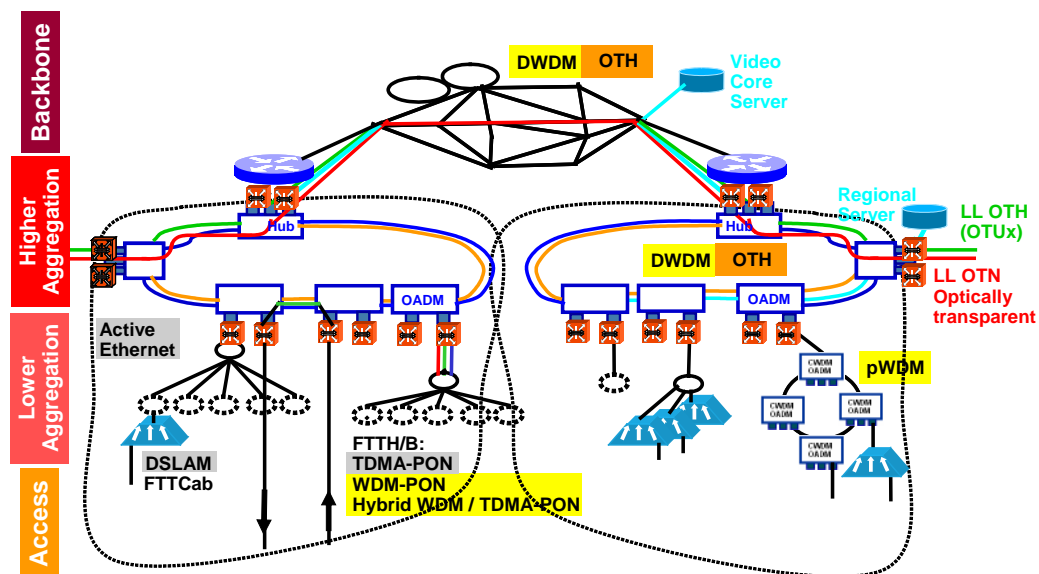

## Goals:

- Cross-layer, cross-domain optimization to deliver efficient and cost-effective bandwidth
- Improved techniques for monitoring at the physical optical layer to support intelligent routing and re-provisioning decisions

# Potential CIAN Technology Insertion - Some Examples

## Tunable VCSELs

- HCG approach increases yield
- Optimized nanocantilever design can provide 1GHz tuning rates
- Tuning range of 80 nm

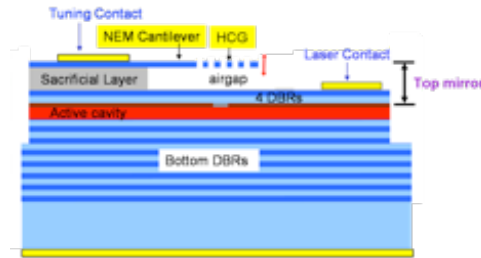

*HCG-MEMS VCSEL*

## Silicon Photonics

- Robust technology compatible with CMOS
- Ultra-compact passive elements (i.e. filters) readily designed and fabricated
- Increase functionality through hybrid integration

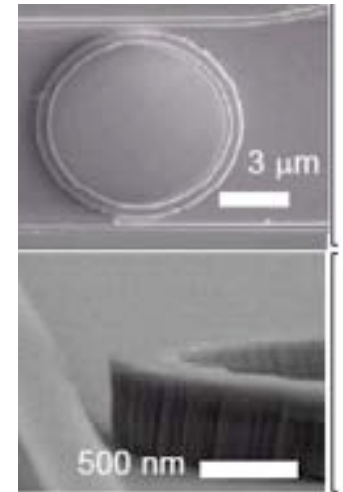

*SOI microring DWDM filter*

## Hybrid EO polymer modulators

- State-of-the art EO polymers with  $r_{33} \sim 10 \times \text{LiNbO}_3$
- Sub-volt modulation up to 40GHz and beyond
- Can be integrated with sol-gel, IOX glass, and silicon platforms

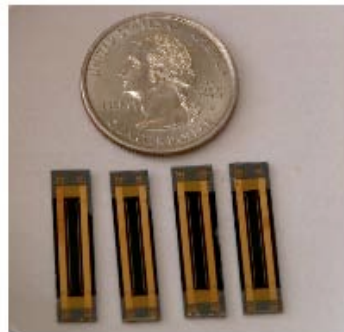

*Sub-volt EO modulators on Si*

## III-V/Si Integration

- Leverage MEMS assembly expertise
- Integrated microdisk lasers with silicon photonic substrates
- 100mW powers already demonstrated

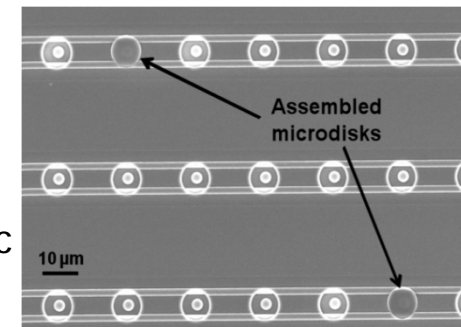

*InGaAs microdisks integrated on Si*



# EOE Communication

5 mm

On-chip Interconnect

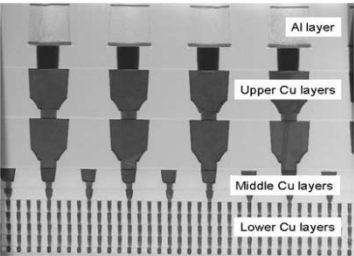
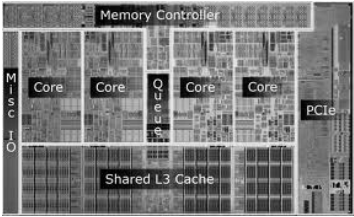

Global Wires:  
core-to-core,  
core-to-cache, IO

10 mm

Multi-chip module

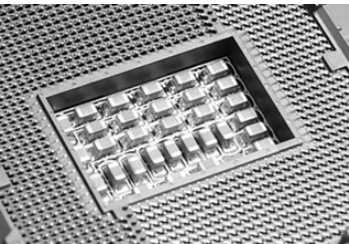
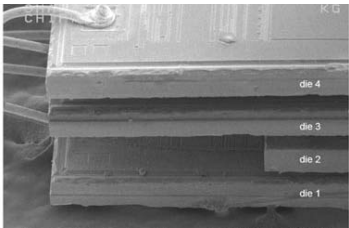

Chip-to-chip interconnects  
in a multi-chip  
module (MCM)

5 cm

Chip-to-board

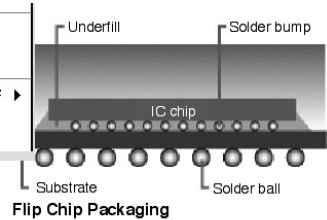
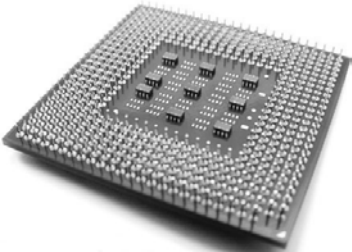

Chip-to-board  
interconnects through  
a substrate

~30 cm

Board-to-board

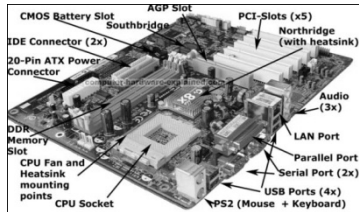
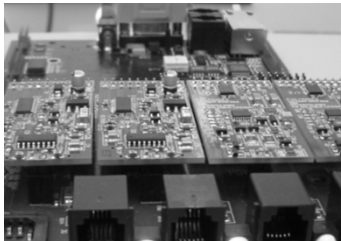

Replace system buses  
To connect between  
boards



# Generic optical substrate implements several levels of interconnect

- IC block to IC block (within single Si die)
- Die-to-die in a multi-chip module (MCM)
- MCM to board - both electrical and optical interconnects are available.

Ball and pad interconnects on the optical substrate assure back-compatibility for regular flip-chip interconnects to the board.

Schematic of an **optical substrate**

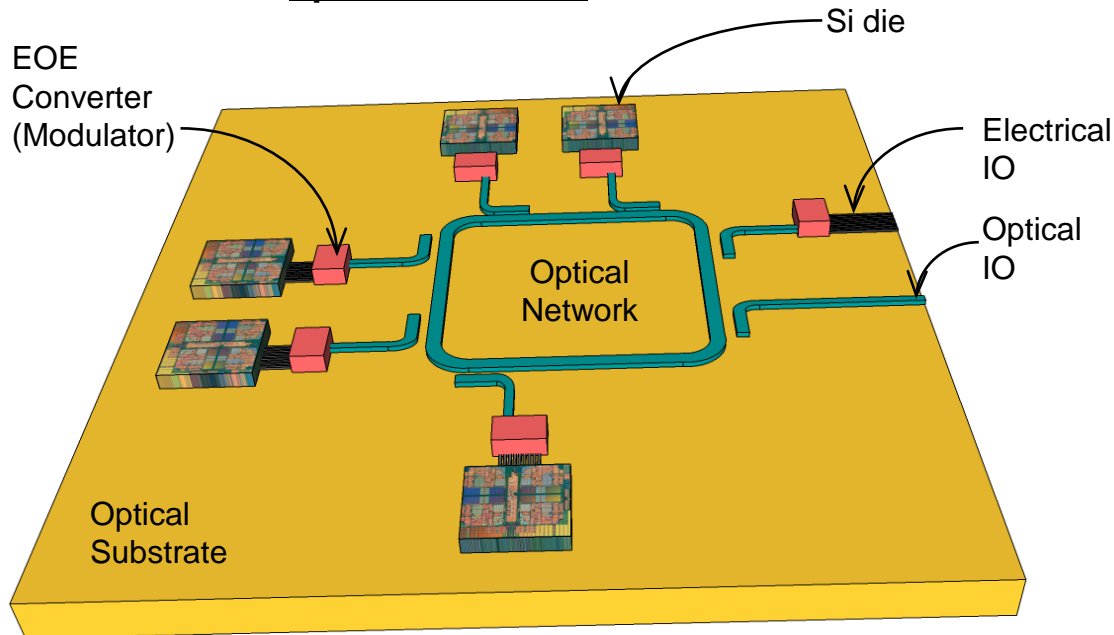

# Chip-scale 1x4 channel add-drop multiplexers

Demonstration of chip-scale 1x4 channel add-drop multiplexer for WDM links

## Design

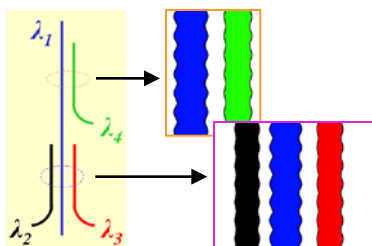

## FDTD Simulations

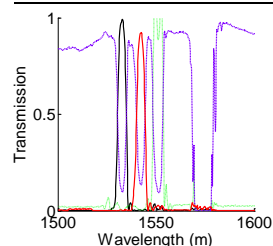

## Fabricated Structures

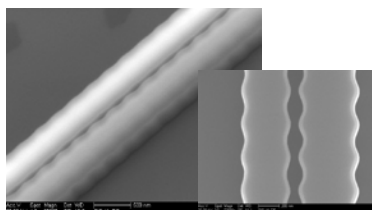

## Experimental Results

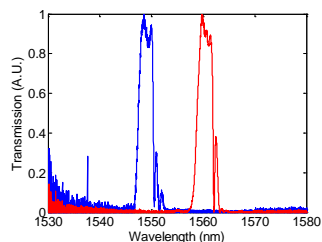

## Accomplishments

- Chip-scale channel add/drop multiplexers based on waveguide Bragg gratings were demonstrated.
- Design for manufacturability based on low-cost high-volume CMOS manufacturing was developed.

## Design for manufacturability

### Agreement of design with the fabricated structures

- 3D simulations: ~0.2% accuracy in the wavelength
- 2D simulations: ~25nm of wavelength shift, ~30% inaccuracy in the line width

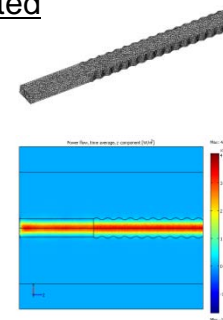

### Approach to minaturization of the device by folding was developed and demonstrated.

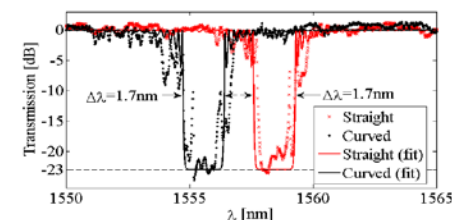
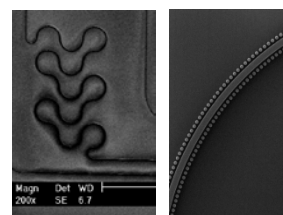

## Opportunities and Future Work

- Application of the device to non-linear optics on-chip
- Construction of hybrid Si-III-IV lasers.

# Data Introspection for Access Networks

## Overarching Goals

- A vulnerable, single interface (i.e., single point of failure) typically exists between the core and access networks.
- Advanced optical performance monitoring, OPM, (i.e., data introspection) can rapidly measure the physical health of the network, the quality of data signals, and isolate the specific cause of impairment.
- This knowledge can potentially assist the network to diagnose and repair the failures, reroute the traffic, and enable cross-layer QoS network optimization.
- OPM module can be efficiently integrated into the access network interface.

## Technical Approach



- Impairments will affect data's spectral components, which can be analyzed using filters.
- Use tunable optical and RF filters, delay-line interferometers (DLI), and power meters.
- Simultaneously monitor OSNR, chromatic dispersion (CD) and polarization mode dispersion (PMD) for different data formats (amplitude and phase shift keying, polarization multiplexing).
- Work with *Thrusters 2/3* to integrate the required photonic components.

## Results of Advanced OPM

- (i) USC demonstrated OSNR monitor for multiple formats (i.e., ASK, PSK). It was implemented in Columbia's testbed.
- (ii) USC demonstrated PMD monitor for 80-Gbit/s pol-muxed PSK signals using degree-of-polarization (DOP). Monitor is less sensitive to other impairments and is scalable to high data rates and various formats.

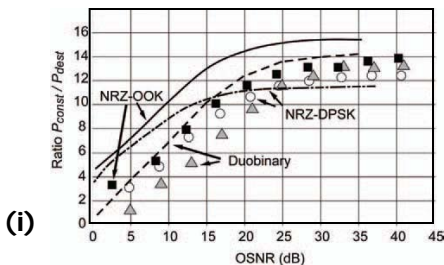

(i)

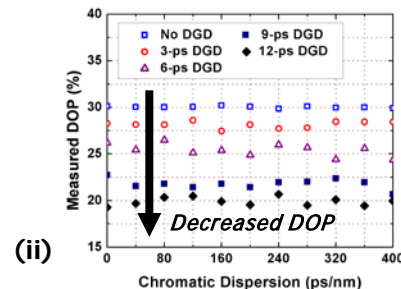

(ii)

## Columbia/USC Collaboration

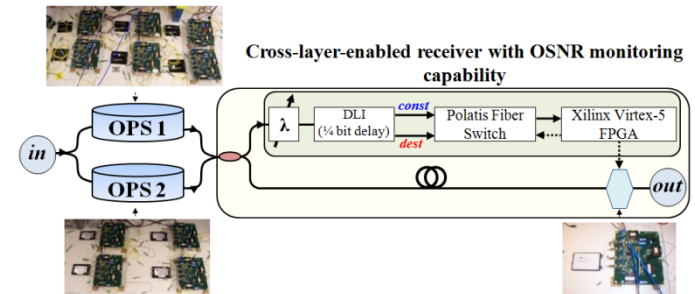

- We have demonstrated OSNR-monitor-enabled, real-time cross-layer QoS optimization for routing of 10-Gbit/s data packets.
- Plans exist for implementing CD and PMD monitors into a 40-Gbit/s OPS testbed.



# A Plan for Realizing the Future

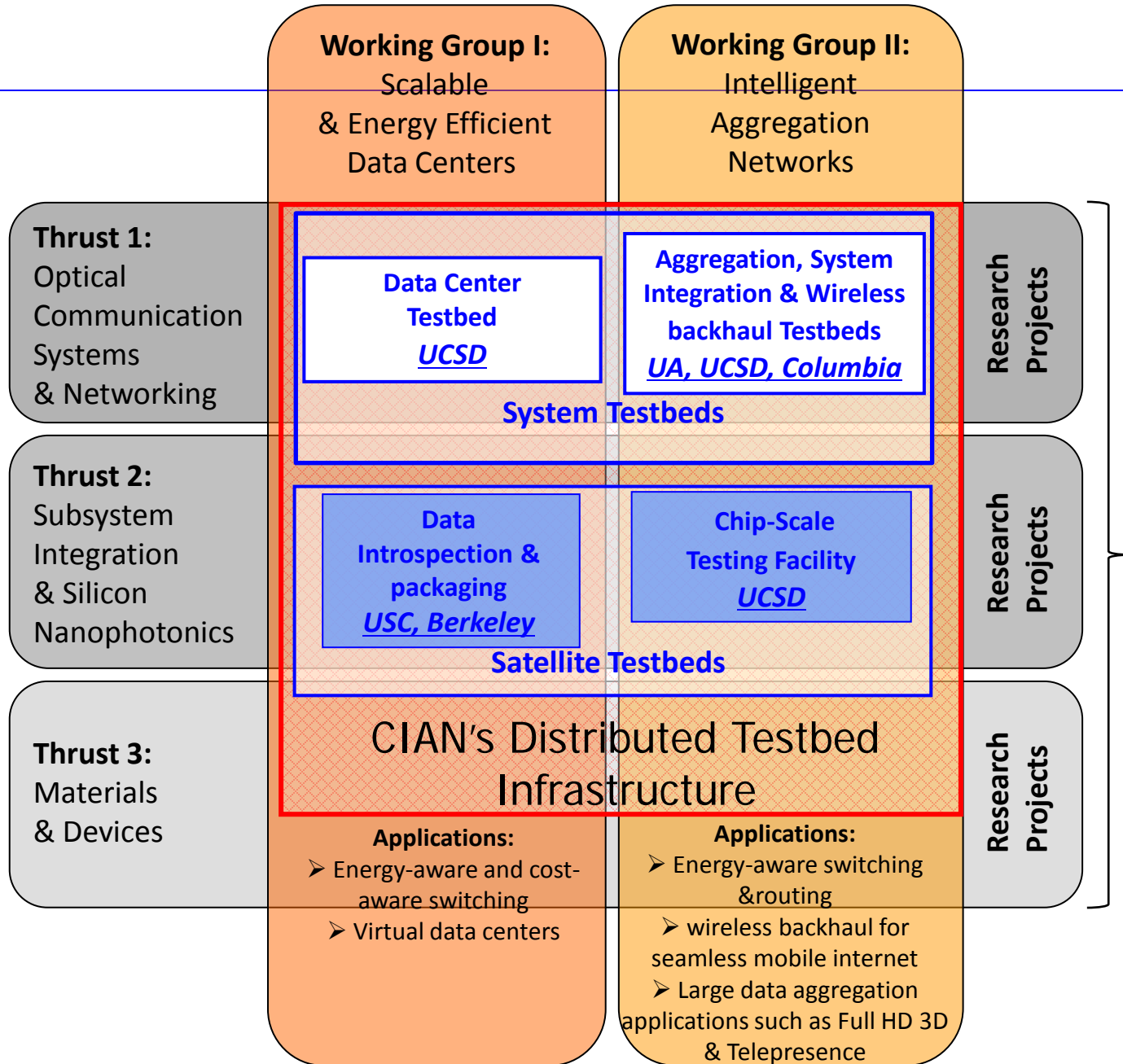

# Goals of the Industrial Affiliates Program

---

- Economic Growth
- New Business Opportunities for Industry
- Entrepreneurship Development
- Research Technology Transfer
- Facilitate hiring highly trained graduates



# Drive the Innovation Pipeline!

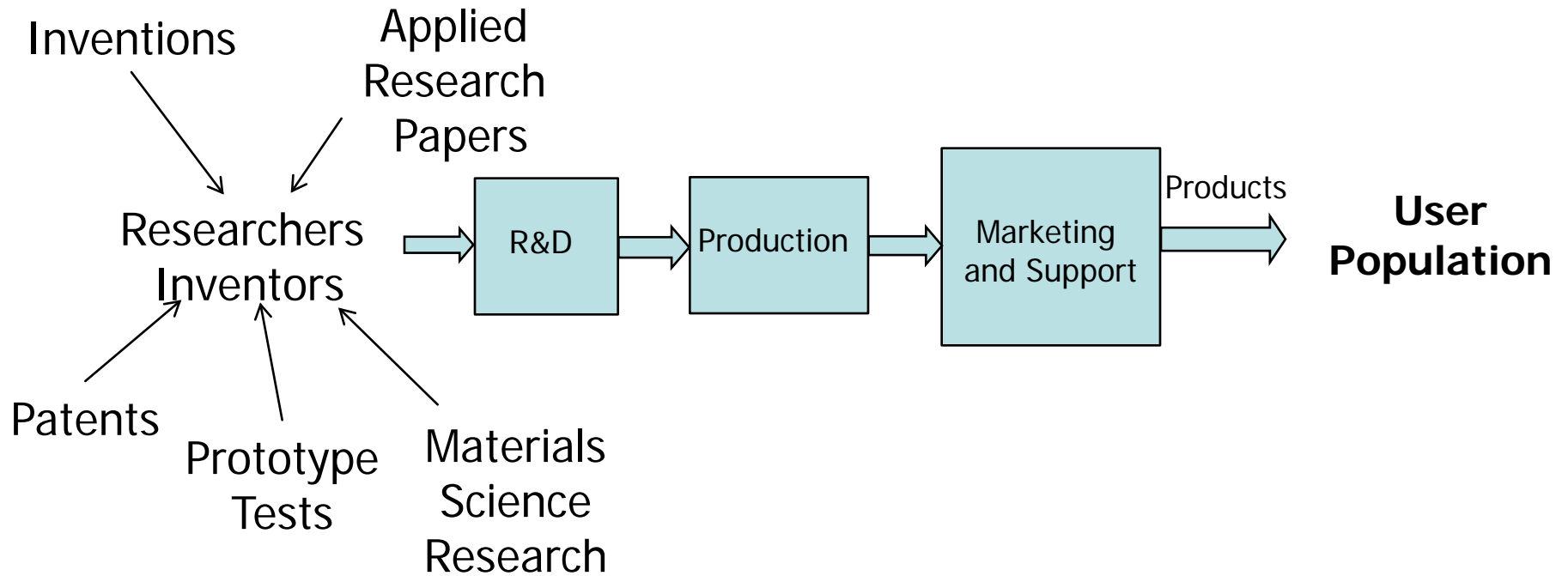

Collaboration Improves  
Technology Adoption Success

Portions taken from: The Innovators Way, Peter J. Denning and Robert Dunham, The MIT Press , Cambridge Mass, 2010



# CIAN Technology Transfer Process

## Shared Responsibilities

Prove Principles                      Prove Application                      Implement and Reproduce Application

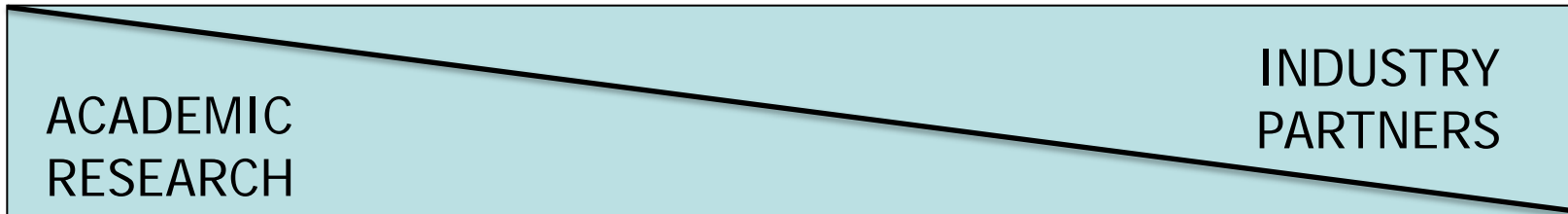

$$\begin{aligned} \nabla \cdot \epsilon \mathbf{E} &= \rho \\ \nabla \cdot \mu \mathbf{H} &= 0 \\ \nabla \times \mathbf{E} &= -\mu \frac{\partial \mathbf{H}}{\partial t} \\ \nabla \times \mathbf{H} &= \mathbf{J} + \epsilon \frac{\partial \mathbf{E}}{\partial t} \end{aligned}$$

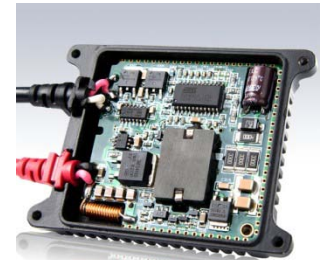
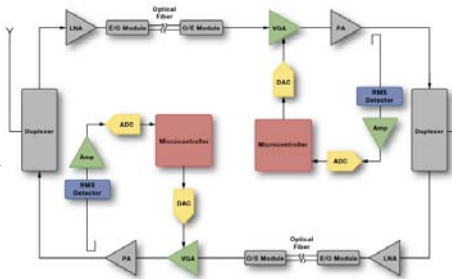
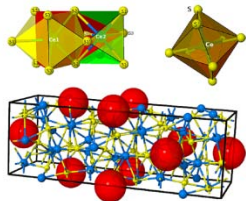

# Industry Membership in CIAN

Status

## Prospects

## In Discussions

## IAB Members

Avago Optical Air Data Systems Yahoo! I/O Data Centers OpNext Lockheed Martin National Instruments Telcordia Thorlabs Simply Bits CrossFire	Hewlett Packard Alcatel/Lucent Intel Ericsson Qualcomm	Fujitsu Nitto Denko Agilent Luxdyne
IBM AboveNet	Google Magnolia Telemetry Boeing	FNE Kotura Yokogawa  <i>Just arrived:</i> VPI Systems GigOptix Sun/Oracle



# CIAN Membership Benefits

---

## TECHNOLOGY RESEARCH LEVERAGE

- For member company, the CIAN management provides a single interface to several CIAN Universities, applies CIAN resources, sets-up and manages associated projects
- CIAN provides individual PI research, and access to the combined expertise from several PIs across CIAN Universities to deliver a system solution

## KNOWLEDGE TRANSFER

- CIAN supports Industrial Partner's access to Intellectual Property
  - Assisted search and review of Intellectual Property of CIAN
  - Transfer of know-how from access to researchers
  - Professor lectures at company for staff training



# CIAN Membership Benefits (Cont'd)

---

## **COST EFFECTIVE AND FAST PROTOTYPE TESTING**

- Use of most advanced system test beds at CIAN institutions
  - Documented test capabilities and test support for new products under development
  - Access to distributed testing infrastructure

## **RECRUITMENT OF TOP STUDENTS**

- Access to BS, MS and PhD students trained by CIAN institutions for technical skills, inter-disciplinary teamwork, and other critical skills important to industry
  - Vetted candidates for summer internship and permanent employee positions
  - Member company can learn about skills of candidates prior to hiring



# Why Collaborate?

---

## COMPANY STRATEGISTS

- Business opportunities
- Advancement
- Large ROI: \$25K/year fee allows access to \$40M in research

## CIAN RESEARCHERS

- Visibility in Industry
- Publications used by others
- Satisfaction that inventions are adopted
- Optimize funding of projects



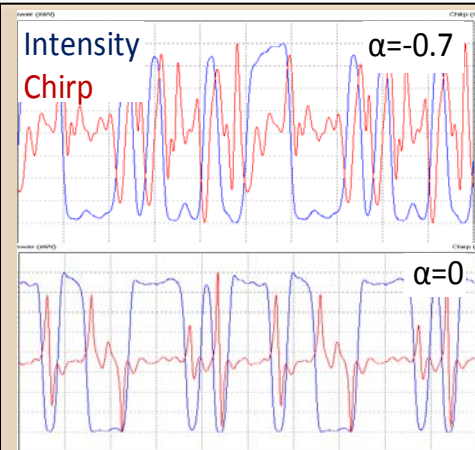

Tunable frequency chirp via RF drive signal phase and amplitude adjustment @ 80 Gbit/s for NRZ-OOK. (Blue: intensity, red: chirp)

## Goals

- $\geq 100$  GSymbol signal generation using electronic and optical time division multiplexing.
- Utilize polymer technology for high bandwidth and low voltage access network components.
- Use dual-drive and I/Q modulators capable of  $\geq 100$  GSymbol modulation for advanced optical modulation formats.

Bit-error-rate measurements for ETDM 80 Gbit/s NRZ-OOK and NRZ-DPSK

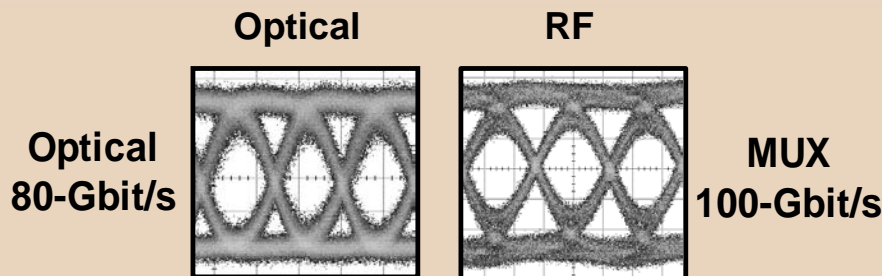
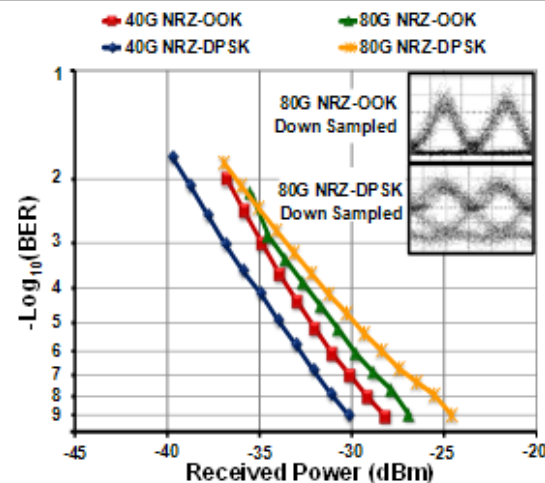

## Achievements

- Demonstrated  $\geq 80$  Gb/s ETDM OOK and DPSK serial modulation and transmission.
- $\geq 100$  GHz of EO polymer modulation bandwidth.
- Demonstrated tunable frequency chirp at  $\geq 80$  Gb/s for increased impairment tolerance and access network performance.